



Modular Cooking Range Line 900XP 2-Burner Gas Boiling Top with 3mm worktop and electric ignition

ITEM # _____

MODEL # _____

NAME # _____

SIS # _____

AIA # _____



391240 (E9GCGDTC00)

2-Burner (6 kW each) gas
Boiling Top with 3mm
WorkTop and electronic
ignition

Short Form Specification

Item No. _____

To be installed on open base installations, bridging supports or cantilever systems. High efficiency flower flame burners with continuous power regulation and optimized combustion. Flame failure device as standard on burners to protect against accidental extinguishing. Electronic ignition for burners. Exterior panels of unit in stainless steel with Scotch Brite finish. Pan supports in heavy duty cast iron. Extra strength work top in heavy duty 3 mm stainless steel. Right-angled side edges to allow flush-fitting junction between units.

Main Features

- Unit to be mounted on open base cupboards, bridging supports or cantilever systems.
- The two 6 kW high efficiency flower flame burners are available in two different sizes to suit high performing cooking requirements of the most demanding customers:
 - 60 mm burners with continuous power regulation from 1,5 to 6 kW
 - 100 mm burners with continuous power regulation from 2.2 kW to 10 kW
- Gas appliance supplied for use with natural or LPG gas, conversion jets supplied as standard.
- Large sized pan support in cast iron (stainless steel as option) with long center fins to allow the use of the largest down to the smallest pans.
- Burners with optimized combustion.
- Flame failure device on each burner protects against gas leakage when accidental extinguishing of the flame occurs.
- The special design of the control knob system guarantees against water infiltration.
- IPX5 water protection.
- Suitable for countertop installation.

Construction

- Unit is 930 mm deep to give a larger working surface area.
- All exterior panels in Stainless Steel with Scotch Brite finishing.
- Model has right-angled side edges to allow flush fitting joints between units, eliminating gaps and possible dirt traps.
- Electric ignition.
- AISI 304 stainless steel worktop, 3mm thick.

APPROVAL: _____



Experience the Excellence
www.electroluxprofessional.com

Optional Accessories

• Junction sealing kit	PNC 206086	<input type="checkbox"/>
• Draught diverter, 120 mm diameter	PNC 206126	<input type="checkbox"/>
• Matching ring for flue condenser, 120 mm diameter	PNC 206127	<input type="checkbox"/>
• Support for bridge type installation, 800mm	PNC 206137	<input type="checkbox"/>
• Support for bridge type installation, 1000mm	PNC 206138	<input type="checkbox"/>
• Support for bridge type installation, 1200mm	PNC 206139	<input type="checkbox"/>
• Support for bridge type installation, 1400mm	PNC 206140	<input type="checkbox"/>
• Support for bridge type installation, 1600mm	PNC 206141	<input type="checkbox"/>
• Support for bridge type installation, 400mm	PNC 206154	<input type="checkbox"/>
• Single burner radiant plate for pan support	PNC 206170	<input type="checkbox"/>
• Single burner smooth plate for direct cooking - fits frontal burners only	PNC 206171	<input type="checkbox"/>
• Single burner ribbed plate for direct cooking - fits frontal burners only	PNC 206172	<input type="checkbox"/>
• Water column with swivel arm (water column extension not included)	PNC 206289	<input type="checkbox"/>
• Water column extension for 900 line	PNC 206290	<input type="checkbox"/>
• Stainless steel double grid for 2 burners	PNC 206298	<input type="checkbox"/>
• Chimney upstand, 400mm	PNC 206303	<input type="checkbox"/>
• Back handrail 800 mm	PNC 206308	<input type="checkbox"/>
• Back handrail 1200 mm	PNC 206309	<input type="checkbox"/>
• Flue condenser for 1/2 module, 120 mm diameter	PNC 206310	<input type="checkbox"/>
• Wok pan support for open burners (700/900)	PNC 206363	<input type="checkbox"/>
• Kit town gas nozzles (G150) for 900 gas boiling top	PNC 206384	<input type="checkbox"/>
• Chimney grid net, 400mm (700XP/900)	PNC 206400	<input type="checkbox"/>
• Side handrail-right/left hand (900XP)	PNC 216044	<input type="checkbox"/>
• Frontal handrail, 400mm	PNC 216046	<input type="checkbox"/>
• Frontal handrail, 800mm	PNC 216047	<input type="checkbox"/>
• Frontal handrail, 1200mm	PNC 216049	<input type="checkbox"/>
• Frontal handrail, 1600mm	PNC 216050	<input type="checkbox"/>
• Large handrail - portioning shelf, 400mm	PNC 216185	<input type="checkbox"/>
• Large handrail - portioning shelf, 800mm	PNC 216186	<input type="checkbox"/>
• 2 side covering panels for top appliances	PNC 216278	<input type="checkbox"/>
• Drilled false bottom half module for bain-marie	PNC 921622	<input type="checkbox"/>
• Pressure regulator for gas units	PNC 927225	<input type="checkbox"/>

Front

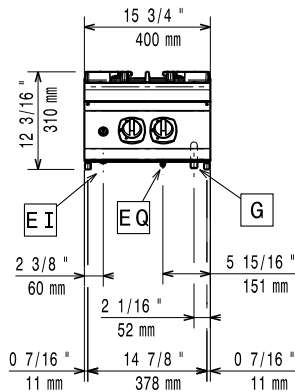

Side

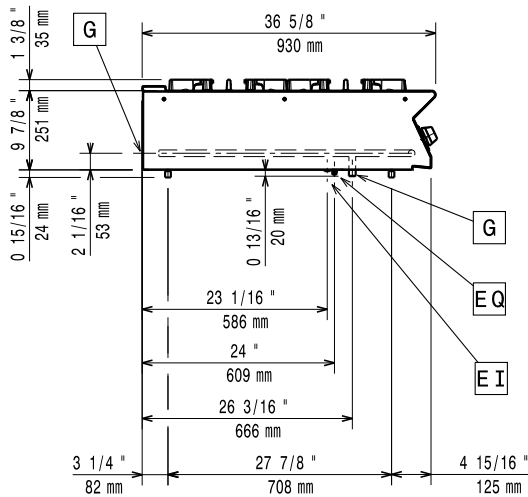

EI = Electrical inlet (power)
 G = Gas connection

Top

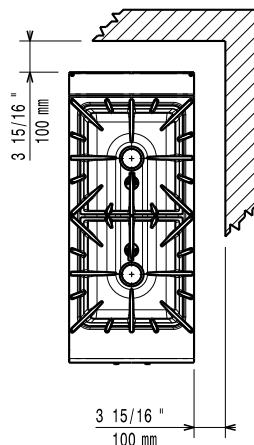

Gas

Gas Power:	12 kW
Standard gas delivery:	Natural Gas G20 (20mbar)
Gas Type Option:	LPG; Natural Gas
Gas Inlet:	1/2"

Key Information:

If appliance is set up or next to or against temperature sensitive furniture or similar, a safety gap of approximately 150 mm should be maintained or some form of heat insulation fitted.

External dimensions, Width:	400 mm
External dimensions, Depth:	930 mm
External dimensions, Height:	250 mm
Net weight:	43 kg
Shipping weight:	45 kg
Shipping height:	540 mm
Shipping width:	1020 mm
Shipping depth:	500 mm
Shipping volume:	0.28 m ³
Front Burners Power:	6 - kW
Back Burners Power:	6 - 0 kW
Certification group:	N9CG
Back Burners Dimension - mm	Ø 60
Front Burners Dimension - mm	Ø 60